

# AX-M800MSO

## Mortise Mount Magnetic Lock

### ► Specification

Dimension	273Lx44Wx27.2H(mm)
Armature plate	190Lx45Wx11H(mm)
Holding Force	350kg(800Lbs)
Voltage	DC12V/DC24V
Current	12V/500mA ; 24V/250mA
Suitable for	Wooden door , Glass door ,Metal door , Fireproof door
Signal Output	Door status detection signal output
Operating Temp	-10~+55°C(14-131F)
Suitable Humidity	0~95%(non-condensing)
Finishes for	Shell Anodized aluminum
Weight	2.7kg

### ► Installation

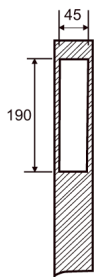

(1) Dig the hole

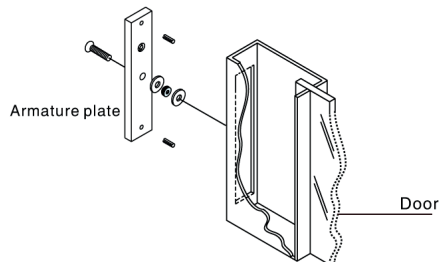

(2) Fix screws

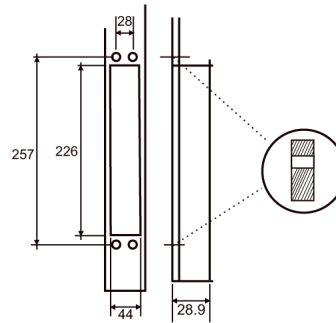

(3) Dig the hole

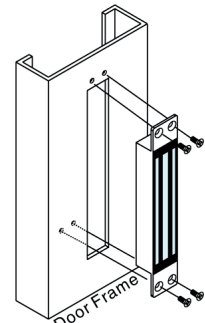

(4) Fix screws

### NOTES:

Please read specification before installing magnetic lock

- A. Handle the equipment carefully. The holding force can be reduced by damaging the lock body or armature plate.
- B. The magnetic lock should be fixed tightly on the door frame and the armature plate on the door leaf. Kit provided allows the armature plate to pivot its center, thus compensating misalignment caused by other factors.
- C. Template can only be used with the door in normally closed circumstance.
- D. Please fix screws of magnetic lock firmly.
- E. Detect signal of door state: the limit of reed switch and dry contact is 0.5A/30VDC. Don't overload.

## ► Circuit board diagram

### A. 12V DC Input

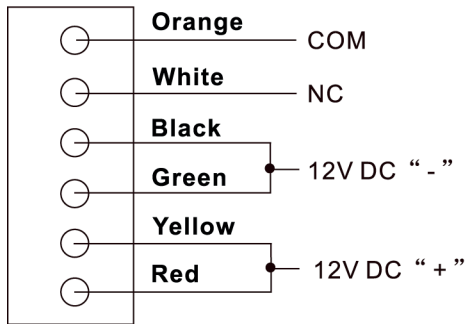

### B. 24V DC Input

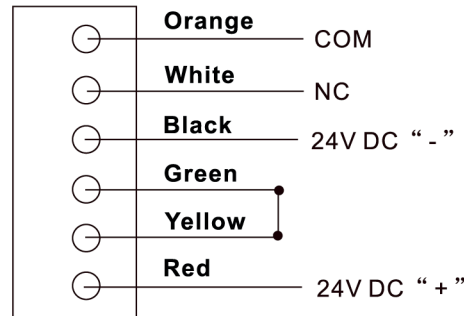

## ► Wire Connection

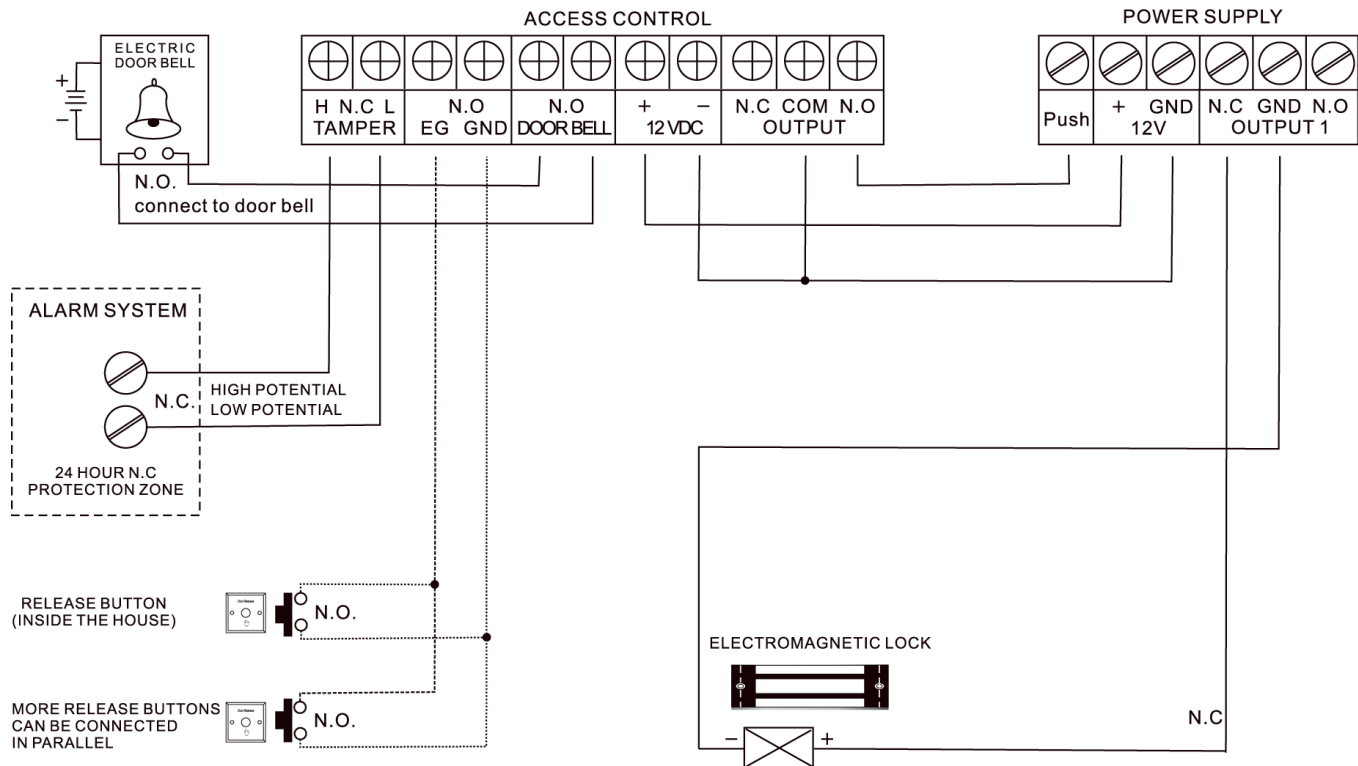

### Cautions:

- The screw of armature plate should not be fixed too tight. Proper elasticity should be guaranteed for the rubber ring so that the armature plate can adjust itself to the appropriate position.
- Check the jumper's position before connecting. Figure out it represents 12VDC or 24VDC.